

Hot milk separators and clarifiers for sound performance

Tetra Centri® AirTight™



AirTight design for high profitability

We deliver reliable separation solutions that enable you to meet your customers' demands for high food quality and safety.

Our range of flexible separators combines high performance with cost efficiency and low environmental impact.

We call it sound performance.



The Tetra Centri AirTight separator for hot milk delivers excellent product quality, superior separation efficiency and unmatched production flexibility.

Excellent product quality

Thanks to AirTight design, Tetra Centri hot milk separators and clarifiers treat your products very gently. The hermetic seals prevent intake of destructive air. This, combined with a smooth acceleration in the rotating hollow spindle, ensures maintained size of the fat globules and particles. With AirTight design you will, therefore, get a cleaner dairy product with fewer impurities and no increase of free fat and free fatty acid. In short, gentle treatment resulting in excellent product quality.

Superior separation efficiency

When it comes to efficiency, no centrifugal separator is better than Tetra Centri. In an AirTight separator, the separability of fat (down to 0.04 % fat in skim) and impurities is outstanding, compared to other designs on the market. This is a result of the gentle product treatment and the fact that the product is extracted from the centre of the bowl.

The AirTight design is also a real energy saver – the separator itself consumes up to 40 %* less than conventional paring disc separators. That reduces the energy consumption of your overall separation system by up to 20 %*. The maintained size of fat globules and particles means that a lower rpm can be used to achieve the desired separation efficiency. In addition, the centred outlet enables a higher recovery of rotational energy. You get maximum separation with minimum energy consumption.

Unmatched production flexibility

Each AirTight separator and clarifier unit handles a wide range of capacities without mechanical modification. Your benefit is that one unit can efficiently handle many capacities and recipes.

The key to this unmatched production flexibility is the use of efficient product discharge pumps, a completely filled bowl and variable rpm control. For instance, the cream fat content in a hot milk separator can be increased to 60 % with maintained skimming efficiency. And if maximum skimming is not required, the rpm can be lowered, saving energy as a result. If cream is pre-concentrated in an AMF line, for example, up to 78 % cream fat can be achieved starting from cream.

Environmental advantages

Tetra Centri AirTight separators not only save you money, they also reduce environmental load. The design reduces energy and water consumption, while minimizing food product loss.

- Power consumption is reduced by up to 20 %* in your overall separation system.
- There is no make-up water consumption – cooling water is reused as seal water
- The accurate discharge results in the lowest possible losses.
- The noise level is very low, approximately 78 dB(A)*, measured according to ISO 3744.

Reliable performance

A Tetra Centri AirTight separator delivers sound performance year after year thanks to easy operation and service. Our skilled service engineers are available whenever you need them, wherever you are.

* Data for Tetra Centri AirTight Eco is presented in a separate brochure

Built for performance

Our continuous research and development, both in machinery and in processing, enables you to meet your toughest demands for quality, efficiency and flexibility. Here's the hardware that gets the job done.

The separator is hermetically sealed, both at the inlet and the outlet. This prevents intake of destructive air. From the inlet, the product is gently fed into the separator bowl through the hollow spindle. As the spindle rotates with the bowl, the product enters the bowl smoothly. This assures that the sizes of fat globules and particles are consistently maintained.

In the bowl, the cream is led all the way to the centre of the bowl, while the skim leaves the bowl over the top disc. Any unwanted particles are collected at the sediment space at the periphery of the bowl. The sediment space is emptied accurately and hydraulically at preset intervals. At the outlets, co-rotating pumps efficiently discharge the separated products from the centre.

All in all, the AirTight design enables gentle and efficient separation.

Hermetic outlet seals
No air entrainment

Corrosion resistant stainless steel bowl
Longer lifetime

Water-filled double jacket
Noise reduction,
less heat emission

Motor for variable frequency drive (VFD)
Proven standard motor used

Pneumatic brake
Can also be braked
by means of VFD

Direct drive
Lower service cost



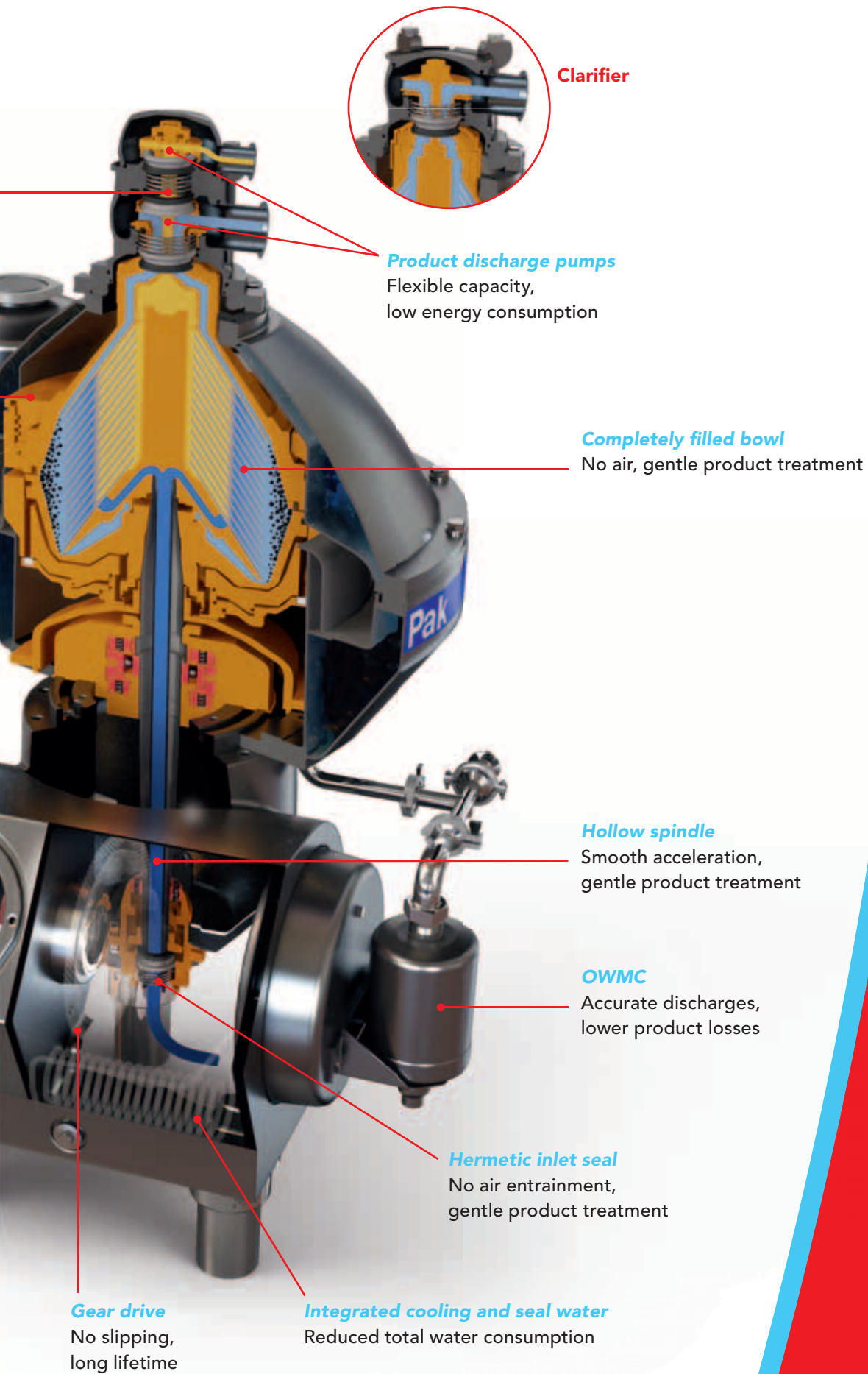

Clarifier

Product discharge pumps
Flexible capacity,
low energy consumption

Completely filled bowl
No air, gentle product treatment

Hollow spindle
Smooth acceleration,
gentle product treatment

OWMC
Accurate discharges,
lower product losses

Hermetic inlet seal
No air entrainment,
gentle product treatment

Gear drive
No slipping,
long lifetime

Integrated cooling and seal water
Reduced total water consumption



*“Tetra Centri separators
are the best choice for
dairies requiring the best
milk skimming efficiency
with the lowest possible
energy consumption.”*

Tetra Centri AirTight facts

CLARIFIERS

Technical data	D20	D25	D714	D45	D60	D70
Flow rate, l/h	20,000	25,000	35,000	45,000	60,000	70,000
Motor rating, kW	18.5	18.5	22	37	37	42
Connections, inlet	63.5	63.5	63.5	63.5	63.5	63.5
Connections, outlet	63.5	63.5	63.5	63.5	63.5	63.5
Sediment space, l	5	5	12	35	35	35
Air pressure, kPa	600	600	600	600	600	600
Overhead hoist, kN	10	10	10	15	15	15
Inlet pressure, max kPa	600	600	600	600	600	600
Outlet pressure, max kPa	600	600	600	600	600	600

SEPARATORS

Technical data	H10	H15	H614	H714	H35	H40	H55	H60	H75
Flow rate, skimming, l/h	7,000	10,000	15,000	20,000	25,000	30,000	35,000	45,000	55,000
Flow rate, standardization, l/h	10,000	15,000	25,000	30,000	35,000	40,000	55,000	60,000	75,000
Motor rating, kW	15	15	18.5	22	22	25	25	37	42
Connections, inlet	63.5	63.5	63.5	63.5	63.5	63.5	63.5	63.5	63.5
Connections, light phase	38	38	38	38	63.5	63.5	63.5	63.5	63.5
Connections, heavy phase	63.5	63.5	63.5	63.5	63.5	63.5	63.5	63.5	63.5
Sediment space, l	5	5	10	10	17	17	17	17	17
Air pressure, kPa	600	600	600	600	600	600	600	600	600
Overhead hoist, kN	10	10	10	10	15	15	15	15	15
Inlet pressure, max kPa	600	600	600	600	600	600	600	600	600
Outlet pressure, max kPa	600	600	600	600	600	600	600	600	600

Dimensions

- Height (overhead hoist), mm 2,800 (614, 714: 2,600)
- Length (service area), mm 2,800
- Width (service area), mm 2,800

Auxiliary equipment

- Set of tools
- Inlet pipe, complete
- Flushing arrangement for axial seals
- Constant pressure unit on outlet
- Light phase control (separator only)
- Connection set
- Tetra Centri Control (separator control)
- Tetra Centri Drive (motor control)

Sound processing performance

Our job is to enable you to develop and improve your products and production.

The component solutions we deliver are specifically designed to:

- treat your products gently
- be as economical with resources as possible
- meet high demands on flexibility – in your present production and via future upgrading possibilities

That's what we call sound performance.