

Instruction Manual



Anderson Instrument Co. Inc.
156 Auriesville Road
Fultonville, NY 12072
1-800-833-0081
Fax 518-922-8997

www.andinst.com

Instrument Model Number _____

Instrument Serial Number _____

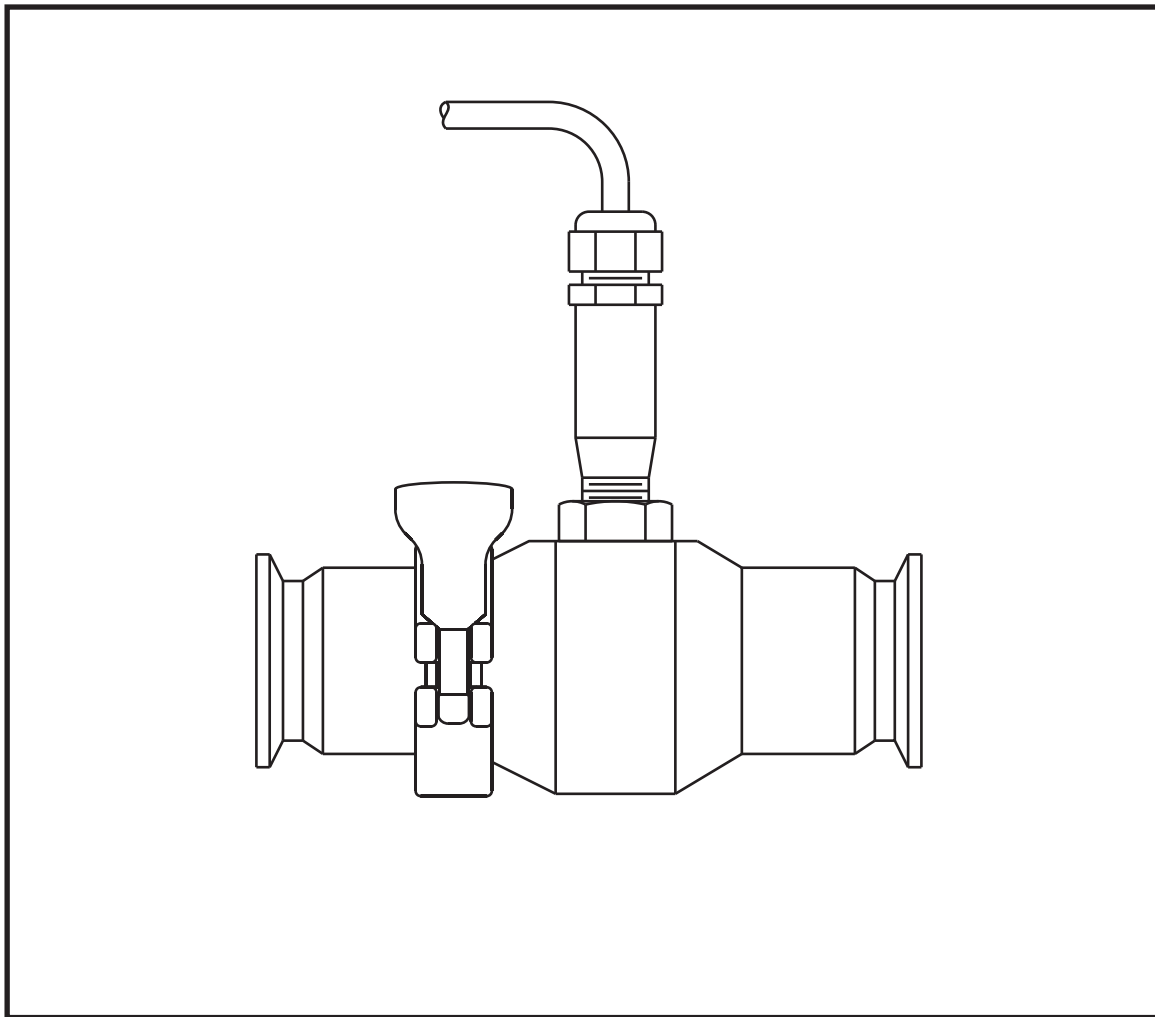

HM TURBINE FLOWMETER



Form Number AIC2051 © 6/04
Effective: October 2011
Supersedes: July 2011

Table of Contents

Section 1 - Specifications	3
1.1 Environmental Specifications	3
1.2 Operational Specifications	4
Section 2 - Introduction	5
2.1 Description	5
Section 3 - Installation	5
3.1 Location	5
3.2 Installation Illustration	5
Section 4 - Electrical Wiring	6
4.1 Signal Probe Wiring	6
4.2 Wiring Diagram	6
Section 5 - Calibration	7
5.1 K-Factor	7
Section 6 - Maintenance	8
6.1 Disassembly	8
6.2 HM Materials List	8
6.3 Assembly	9
6.4 Rotor Wear	9
6.5 Housing Wear	9
Section 7 - Troubleshooting	10
Section 8 - Warranty and Return Statement	11

Section 1 - Specifications

1.1 ENVIRONMENTAL SPECIFICATIONS

POWER / SIGNAL

HTS1000

Supply Voltage:	8-24 VDC, 0.8 Watts maximum
Signal Output:	7.3-23.3 VDC, Unscaled, Pulsed Output
Output Units:	Pulses Per Volume
Ambient Temperature Range:	-40 - 175°F (-40° - 79°C)

HT75000

Supply Voltage:	None
Signal Output:	0.18-2.6 V.P.P, Unscaled, Frequency Output
Output Units:	Pulses Per Volume
Ambient Temperature Range:	-65 - 225°F (-54° - 107°C)

1.2 OPERATIONAL SPECIFICATIONS

RANGE:

MODEL	METER SIZE	SANITARY CLAMP CONNECTION	FLOW RANGE
HM075	3/4"	1"	5-17 GPM (18.5-65 LPM)
HM100	1"	1"	7-70 GPM (26.5-265 LPM)
HM150	1-1/2"	1-1/2"	13-130 GPM (49-492 LPM)
HM200	2"	2"	25-250 GPM (94-946 LPM)

Accuracy:	+0.50% of rate Over Entire Flow Range
Repeatability:	+0.10%
Maximum Product Temperature:	300°F (149°C)
Maximum Inlet Pressure:	150 psi (10.3 Bar)
Maximum Product Viscosity:	100 cps

MATERIAL / CONSTRUCTION

Housing:	316L Stainless Steel
Rotor:	316L Stainless Steel
Gasket:	Silicone
Bearing Sleeve:	Rulon® 123 (reinforced Polytetrafluoroethylene)
Adhesive:	GSP 1325-2 (Epoxy Resin)
Process Connection:	Sanitary Clamp Connections
Ratings:	3-A compliant, Third party verified in accordance with standard 28-03

FIGURE 1.2 TURBINE DIMENSIONS

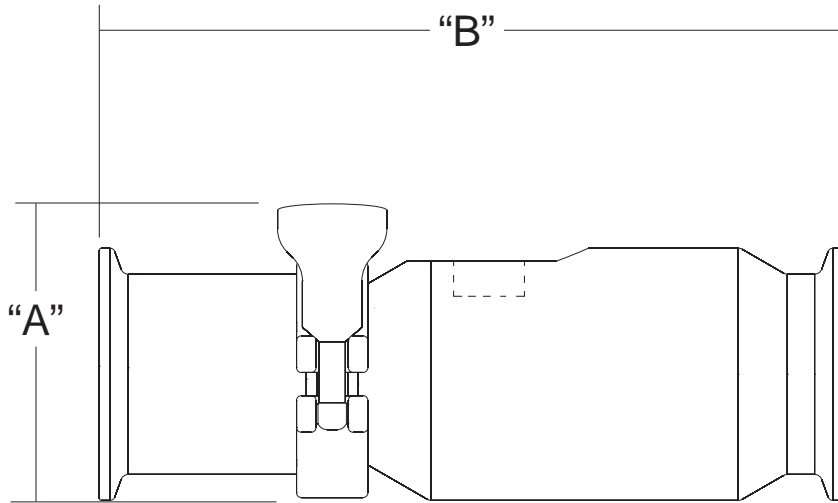

MODEL	DIM "A"	DIM "B"	FITTING
HM075 HM100	3.25" (82.6mm)	5.88" (149.4mm)	1" T.C.
HM150	3.63" (92.2mm)	6.13" (155.7mm)	1 1/2" T.C.
HM200	3.88" (98.6mm)	8.63" (219.2mm)	2" T.C.

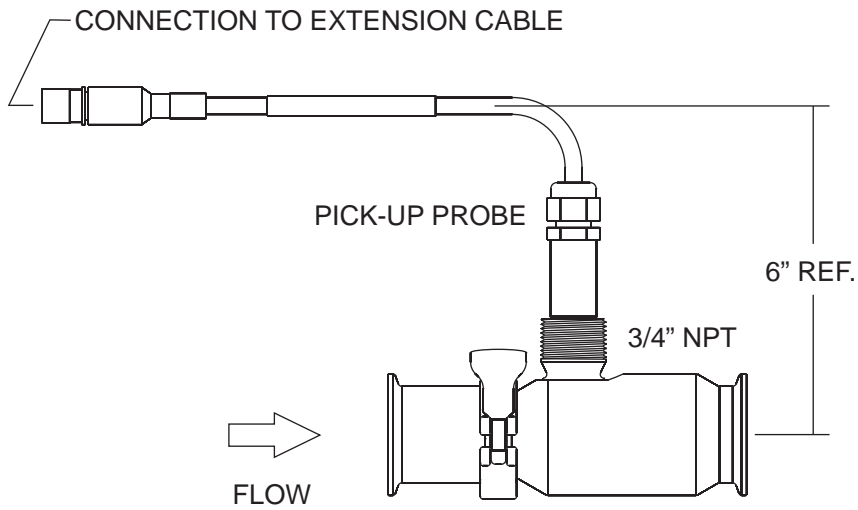

Section 2 - Introduction

2.1 DESCRIPTION

The HM is a volumetric turbine flowmeter. As liquid flows through the meter, it causes the rotor to spin. An external non-contact pick-up probe counts each passing vane of the rotor as it spins. Each revolution of the rotor equates to an exact volume of liquid. This digital signal may feed instrumentation such as controllers or digital indicators. The sealed probe and stainless construction meet the demands of damp or wet applications, and may be directly washed down during normal cleanup. Units are shipped pre-calibrated from the factory with a pulse per gallon value identified on the body.

Section 3 - Installation

3.1 LOCATION

The HM turbine series flowmeter provides accurate measuring results when installed in either a vertical or horizontal pipe section. Select a location where the meter body will be completely filled with product (see figure 3.2). There must be a rise of pipeline elevation from the outlet side of the meter. Avoid the presence of air, either bulk or entrained, from entering the product as it passes through the flow tube.

In a vertical pipe section, install the meter body in the upward direction of flow. In a horizontal pipe section, install the meter body at the lowest possible point of the piping system.

Be sure the arrow on the body of the meter points in the direction of flow.

Install the meter with a minimum of 10 pipe diameters of straight tubing upstream and 5 pipe diameters of straight tubing downstream. Under normal conditions the meter should be installed in a positive pressure location.

When installing the transducer in the meter body, hand tighten the transducer until it bottoms out. **DO NOT USE A WRENCH**, as you may damage the transducer. Secure the position of the transducer with the hex jam nut.

FIGURE 3.2 INSTALLATION

Guidelines	Installation Illustrations
<p>A Install in a horizontal pipe section at a low point before a rising pipeline to ensure meter body remains full.</p>	
<p>B Install in a vertical pipe section with an upward direction of flow to ensure meter body remains full.</p>	
<p>C Do not install in a horizontal pipe section located at the highest point of pipeline. This location allows air to accumulate in the flow tube which causes measuring errors.</p>	
<p>D Do not install in a vertical pipe section with a downward direction of flow. This location allows air to accumulate in the meter body which causes measuring errors.</p>	

Section 4 - Wiring

4.1 SIGNAL PROBE WIRING

Always route signal cables separate from AC power and AC control circuits. Signal cables must be shielded with the bare shield drain wire grounded on one end and floating on the other end.

NOTE: If it becomes necessary to splice cable connections, be sure to properly solder or join wire connections. Loose connections have the ability to generate false counts.

DIAGRAM 4.2 WIRING DIAGRAM

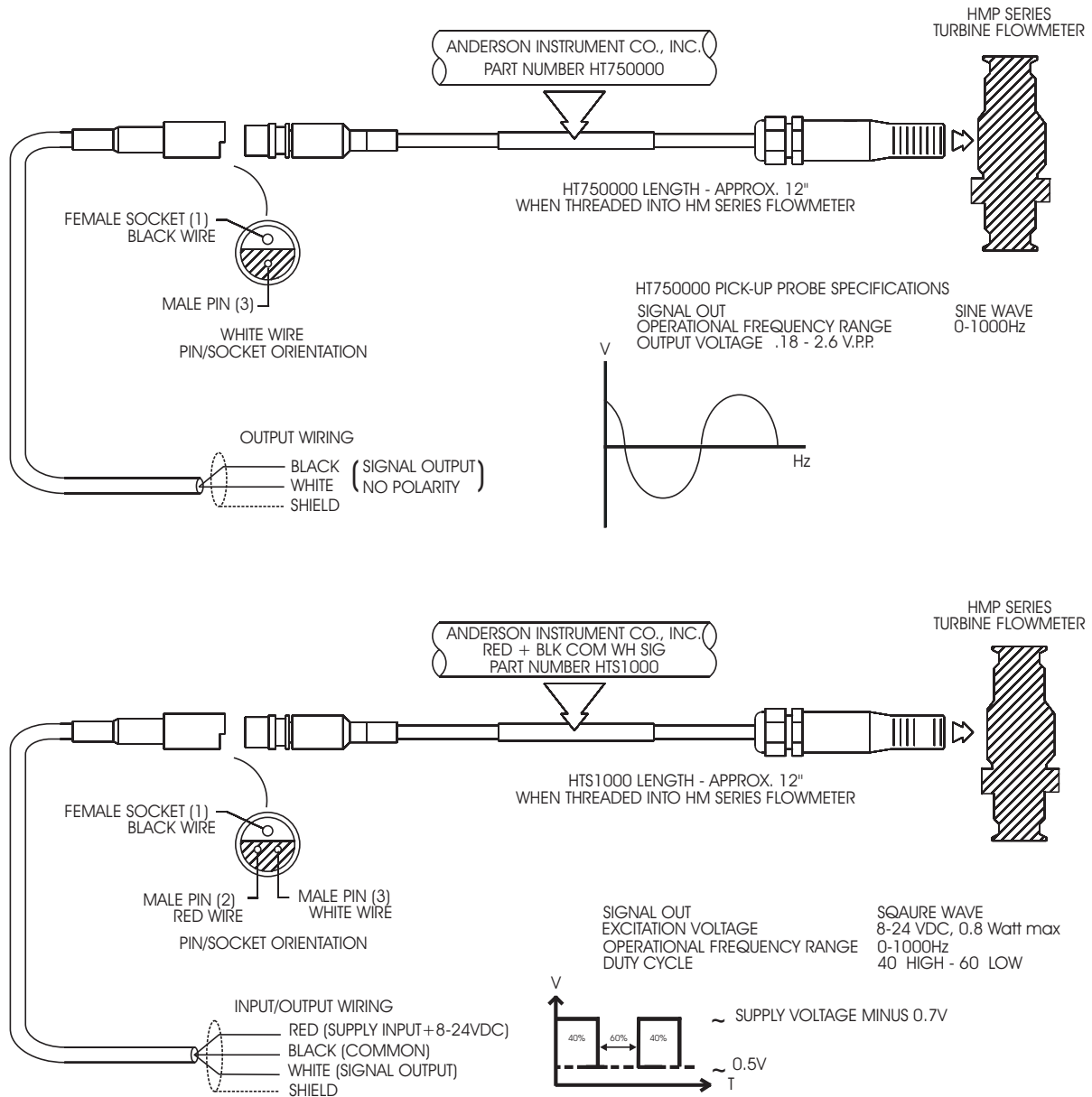

Section 5 - Calibration

The HM flowmeter signal probe detects motion from the rotor to provide a pulsed output. Due to slight changes in meter dimensions, the volume of liquid displaced by the rotor is not the same for every flowmeter. To account for these changes, each meter is flow tested at the factory. A specific numeric value is determined. This identifies the amount of pulses the meter will output per a fixed volume that passes through it. In the case of Anderson flow products a gallon is the volume. This value is labeled on the meter body as a "P/G" pulses per gallon, which is also know as a "K-Factor". Pulsed output values are normally entered into digital converter as a divider value "K-Factor", or as a multiplier value known as a "Scale Factor". Either method converts the unscaled pulses of a flowmeter into the desired engineering unit of your choice, such as gallons, tenths of gallons, liters, etc.

Section 6 - Maintenance

The HM flowmeter, if properly applied, should provide many years of trouble-free service. Excessive flow rates and/or temperature and pressure are conditions which most commonly cause damage to the flowmeter.

6.1 DISASSEMBLY AND INSPECTION

Verify that all line pressure is relieved with all valves closed prior to removal of the meter. Disconnect signal cable and completely remove meter body from the product line. Remove clamp and separate meter housings. Place all items on a clean area for inspection. Rotate flow Straighteners until they fall from the meter housing.

As components are removed from the housing inspect each piece for visible damage.

With the HM turbine wear is typically isolated to the rotor bearing and shaft.

Primarily rotor wear will occur on the inside diameter, or to the downstream side of the bearing. Premature rotor wear is caused by over-ranged flow rates, or abrasive products that would deteriorate the rotor bearing. (Figure 6.4)

Housing damage occurs from a worn rotor. The ID of the rotor can wear to a point where the OD will contact the housing. This condition will immediately diminish the performance of the flowmeter. Prolonged operation under these circumstances can permanently damage the meter housing (Figure 6.5).

FIGURE 6.2 HM MATERIALS LIST

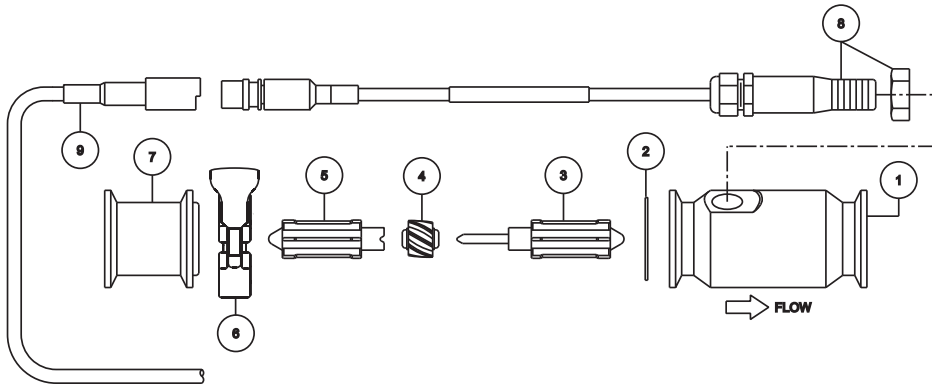

ITEM	HM075 (3/4")	HM100 (1")	HM150 (1.5")	HM200 (2")	DESCRIPTION
1	HM-075-1	HM-100-1	HM-150-1	HM-200-1	METER HOUSING
2	HM-075-2	HM-100-2	HM150-2	HM-200-2	GASKET
3	HM-075-3S	HM-100-3S	HM-150-3S	HM-200-3S	DOWNSTREAM FLOW STRAIGHTENER
4	HM-075-4S	HM-100-4S	HM-150-4S	HM-200-4S	ROTOR
5	HM-075-5S	HM-100-5S	HM-150-5S	HM-200-5S	UPSTREAM FLOW STRAIGHTENER
6	GH13Z-1.5	GH13Z-1.5	GH13Z-2	GH13Z-2.5	CLAMP
7	HM-075-7	HM-100-7	HM-150-7	HM-200-7	FLOW STRAIGHTENER HOUSING
8	HTS1000 (3-WIRE PROBE - INCLUDES JAM NUT)				PICK-UP PROBE
8a	HT75000 (2-WIRE PROBE - INCLUDES JAM NUT)				PICK-UP PROBE
9	CABLE-3W-25 (3-WIRE)				* EXTENSION CABLE STD. 25 FT.
9a	CABLE-2W-25 (2-WIRE)				* EXTENSION CABLE STD. 25 FT.

* CONSULT ANDERSON FOR OTHER OPTIONAL LENGTHS

6.3 ASSEMBLY

Verify the rotor spins freely on the shaft prior to installation. Rotate parts until they fall into place. Match assembly pieces with the orientation shown. (Figure 6.2) **DO NOT FORCE THE PIECES TOGETHER!** Be sure the gasket between the meter housings is in the groove of the body connection area. Secure the housing clamp and reinstall in the process line.

FIGURE 6.4 ROTOR WEAR

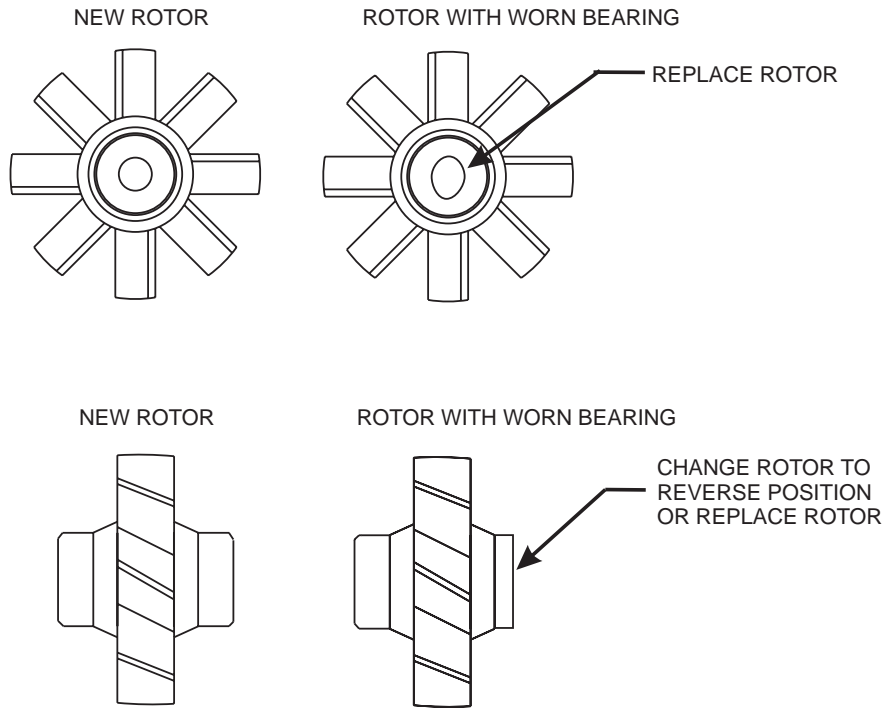
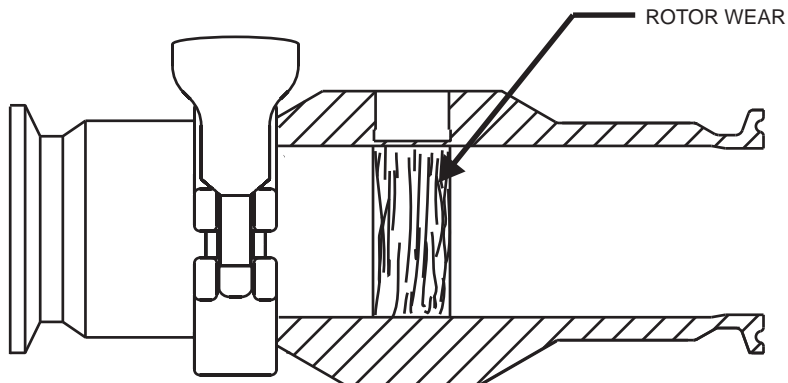

FIGURE 6.5 HOUSING WEAR



Section 7 - Troubleshooting

HM FLOWMETER TROUBLESHOOTING GUIDE

PROBLEM	CAUSE	ACTION
No output or erratic output	<ul style="list-style-type: none"> Failed Probe (no output) Probe not seated Moisture and/or corrosion in probe-to extension cable connector Flow rate too low Obstructed Rotor Incorrect wiring Bad cable splice No scale factor entered Signal interface problem 	<ul style="list-style-type: none"> Replace Probe Check probe: must be threaded to bottom Disconnect extension cable at probe for visual check, dry or clean if required Check meter specification for flow range Check rotor (should spin freely) Check manual for correct wiring configuration Check color code and continuity integrity Check readout device scale factor Check signal input specs of receiving device
HT75000	<ul style="list-style-type: none"> Incorrect coil resistance 	<ul style="list-style-type: none"> Check black/white signal wires for 975Ω
Poor accuracy/ repeatability	<ul style="list-style-type: none"> Air in system Process flow rate out of meter flow range Obstructed Rotor Probe not seated Poor meter installation Poor system hydraulics Incorrect scale factor Electrical noise Changing product characteristics density and/or viscosity Inaccurate proving standard Operating error – poor testing method Rotor wear Damaged housing 	<ul style="list-style-type: none"> Add air elimination device Check meter specs for flow range info (adjust flow rate or change-out meter) Check rotor (should spin freely) Check probe: must be threaded to bottom Locate meter in low spot (see installation) Backflow? (Install check valve) Valve closing time? Check: scale factor, K factor and unit of measure Check: shielding, separate signal from AC wires Check: product weight, viscosity, scale accuracy, control temp. Multiple products? Verify accuracy of proving standard (vessel/ scale) Observe test procedure Remove and inspect (figure: 6.4) Remove and inspect (figure: 6.5)

Section 8 - Warranty and Return Statement

These products are sold by The Anderson Instrument Company (Anderson) under the warranties set forth in the following paragraphs. Such warranties are extended only with respect to a purchase of these products, as new merchandise, directly from Anderson or from an Anderson distributor, representative or reseller, and are extended only to the first buyer thereof who purchases them other than for the purpose of resale.

Warranty

These products are warranted to be free from functional defects in materials and workmanship at the time the products leave the Anderson factory and to conform at that time to the specifications set forth in the relevant Anderson instruction manual or manuals, sheet or sheets, for such products for a period of one year.

THERE ARE NO EXPRESSED OR IMPLIED WARRANTIES WHICH EXTEND BEYOND THE WARRANTIES HEREIN AND ABOVE SET FORTH. ANDERSON MAKES NO WARRANTY OF MERCHANTABILITY OR FITNESS FOR A PARTICULAR PURPOSE WITH RESPECT TO THE PRODUCTS.

Limitations

Anderson shall not be liable for any incidental damages, consequential damages, special damages, or any other damages, costs or expenses excepting only the cost or expense of repair or replacement as described above.

Products must be installed and maintained in accordance with Anderson instructions. Users are responsible for the suitability of the products to their application. There is no warranty against damage resulting from corrosion, misapplication, improper specifications or other operating condition beyond our control. Claims against carriers for damage in transit must be filed by the buyer.

This warranty is void if the purchaser uses non-factory approved replacement parts and supplies or if the purchaser attempts to repair the product themselves or through a third party without Anderson authorization.

Returns

Anderson's sole and exclusive obligation and buyer's sole and exclusive remedy under the above warranty is limited to repairing or replacing (at Anderson's option), free of charge, the products which are reported in writing to Anderson at its main office indicated below.

Anderson is to be advised of return requests during normal business hours and such returns are to include a statement of the observed deficiency. The buyer shall pre-pay shipping charges for products returned and Anderson or its representative shall pay for the return of the products to the buyer.

Approved returns should be sent to: ANDERSON INSTRUMENT COMPANY INC.
156 AURIESVILLE ROAD
FULTONVILLE, NY 12072 USA

ATT: REPAIR DEPARTMENT



ANDERSON INSTRUMENT CO., INC • 156 AURIESVILLE RD. • FULTONVILLE, NY 12072 • USA • 800-833-0081 • FAX 518-922-8997
ANDERSON INSTRUMENT CO. LP • 400 BRITANNIA RD. EAST, UNIT 1 • MISSISSAUGA, ONTARIO L4Z 1X9 • CANADA • 905-603-4358 • FAX 905-568-1652
NEGELE MESSTECHNIK GmbH (A Division of Anderson) • RAIFFEISENWEG 7 • D-87743 EGG A. D. GÜNZ • GERMANY • +49 (0) 8333/9204-0 • FAX +49 (0) 8333/9204-49

www.andinst.com